



Support tableau blanc mobile
Ref. Nat8100



Description produit

Support tableau blanc mobile
Design sobre et contemporain en bois et métal
Permet d'écrire des deux côtés simultanément. Peut aussi servir de cloison séparatrice
Surface laquée effaçable à sec et magnétique. 2 Surfaces d'écriture : 100 x 113cm incluses
Plumier magnétique inclus. Pot à crayon 530M compatible

Dimensions : 100x189x46cm
Poids : 30 kg
Coloris : bois et noir
Certification FSC pour le bois



Modèle disponible

Ref.	Code Cep	Gencod pièce	Gencod carton	Gencod surcarton	Gencod palette
Nat8100	2081005421	8427951810090	TBC	no	

Nomenclature douanière

96100000

Données logistiques

PRODUIT			CARTON				SUR CARTON			PALETTE				
Ref.	Dimensions mm	Poids Unit. Kg	PCB	Dimensions mm	Poids Brut kg	Poids Net kg	PCB	Dimensions mm	Poids Brut kg	Poids Net kg	PCB	Dimensions mm	Poids Brut kg	Poids Net kg
Nat8100	100x189x46	30	1	1490x1090x30 700x160x60	27,7+3,65	NC	NC	NC	NC	NC	12	1500x800	NC	NC



Support mobile



Bords arrondis

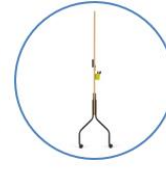

Double face

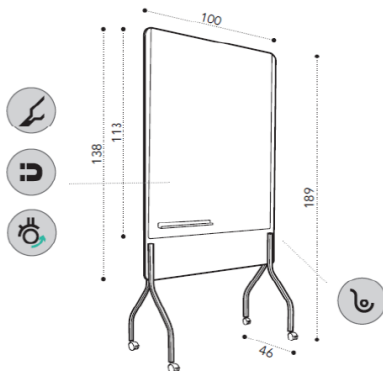

Ne pas nettoyer avec un agent corrosif (alcool)